

基本規格 SPECIFICATIONS

MC-02 系列 SERIES		
最大工作壓力 Maximum Pressure	bar	210 bar (3000 PSI)
最大流量 Maximum Flow	LPM	35 LPM (9.25 GPM)
重量 Weight	型式 Code: P,T	1.0 Kgs (2.2 Lbs)
	型式 Code: A,B,W	1.1 Kgs (2.4 Lbs)
使用油品 Fluid Type		礦物性 耐磨性 Mineral, Anti-Wear
黏度範圍 Viscosity	cST	10-400 cST (59-1854 SSU)
使用溫度 Operating Temperature	°C	-15-70°C (-5-158°F)
清潔度 Contamination Level		NAS 12 級以內 Under NAS Class 12
表面處理 Surface Treatment		磷酸鹽皮膜處理 Zinc Phosphate Compound

型號說明 HOW TO ORDER

MC - 02 P - 05 - 40

① ② ③ ④ ⑤

① 閥系列 Valve Series

MC = 疊加式止逆閥
 Modular Check Valve

② 通稱口徑 Subplate Mounting Size

02 = 通稱 Nominal 1 / 4" (6mm)
 ISO CETOP3
 DIN NG6
 NFPA D03

③ 控制迴路 Control Port

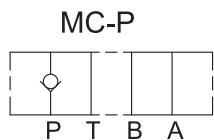

P 迴路控制
 (P Port Only)

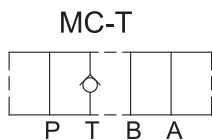

T 迴路控制
 (T Port Only)

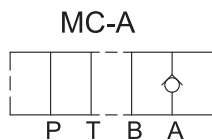

A 迴路控制
 (A Port Only)

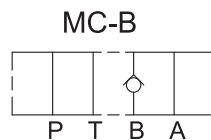

B 迴路控制
 (B Port Only)

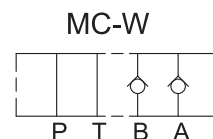

A與B 迴路控制
 (A&B Port)

④ 開啟壓力 Cracking Pressure

05 = 0.35 bar (5 PSI)
 50 = 3.5 bar (50 PSI)

⑤ 設計型號 Design No.

特性曲線 PERFORMANCE

測試條件 Test Conditions

溫度 Oil Temperature: 50°C (122 °F)

黏度 Viscosity: 35cST (163 SSU)

壓力降特性曲線 PRESSURE DROP

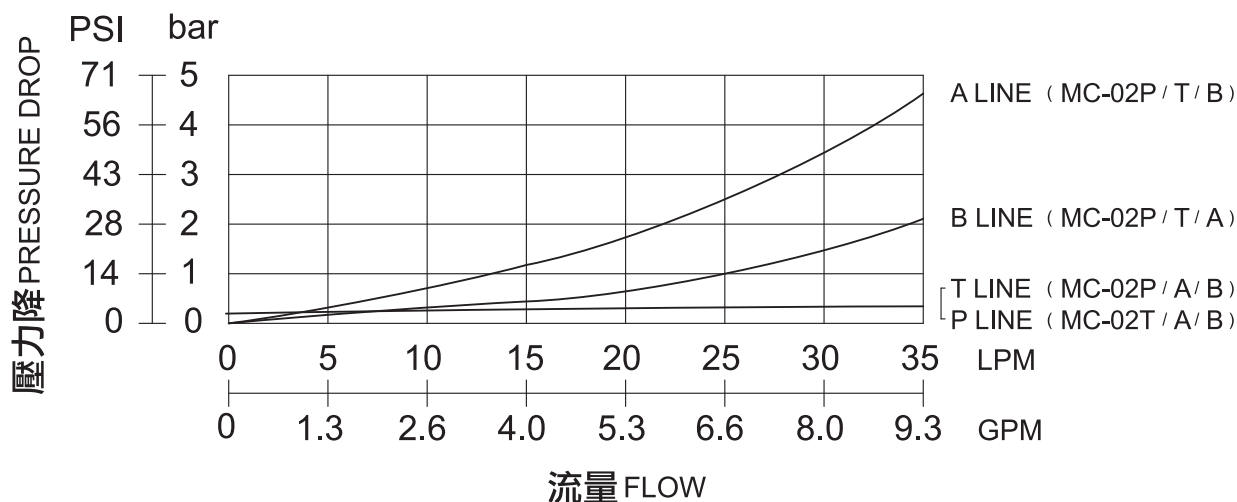

壓力降特性曲線 自由流 (PRESSURE DROP (FREE FLOW))

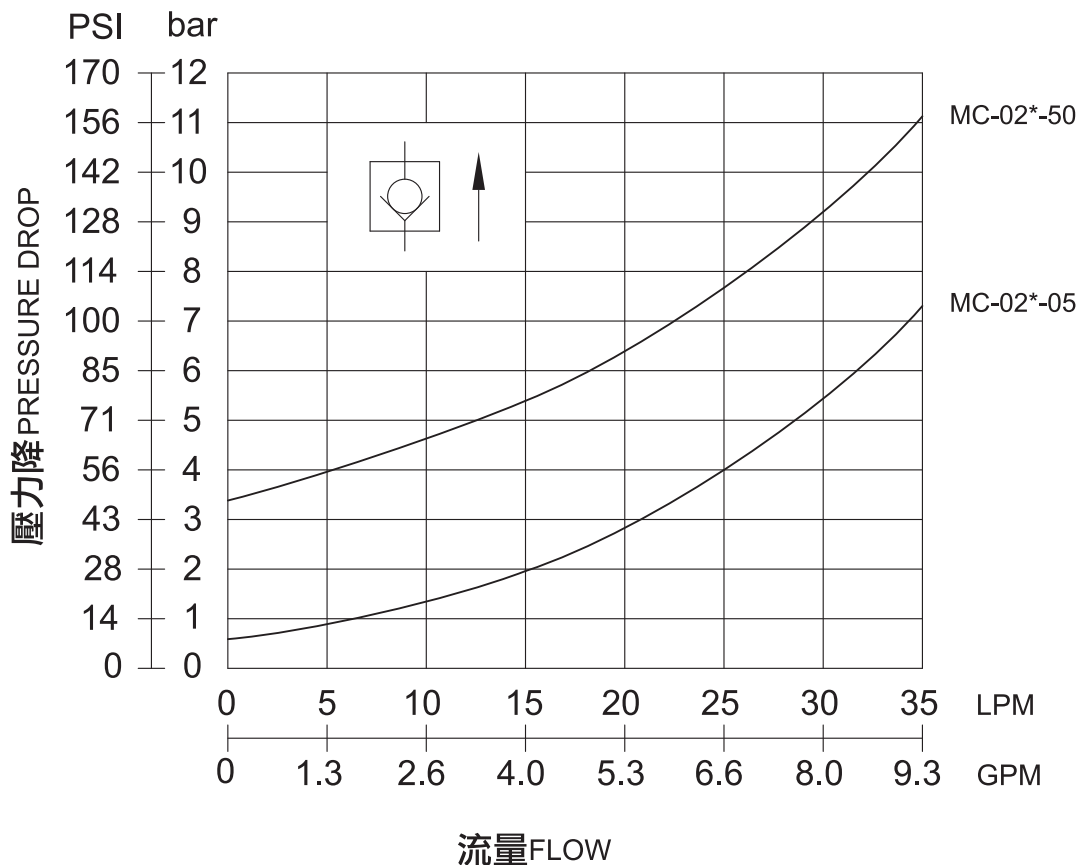

外型尺寸DIMENSIONS

MC-02 W/A/B

安裝面

Mounting Interface:
 ISO 4401-AB-03-4-A

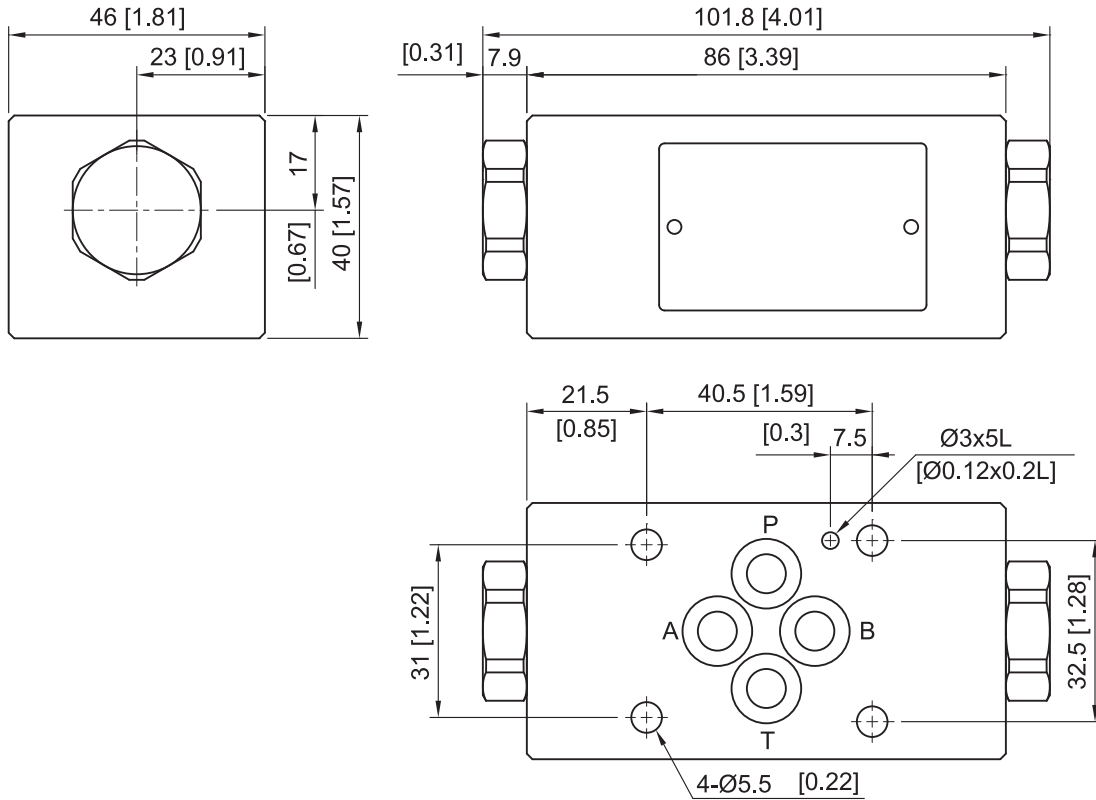

安裝面MOUNTING INTERFACE

ISO 4401-AB-03-4-A

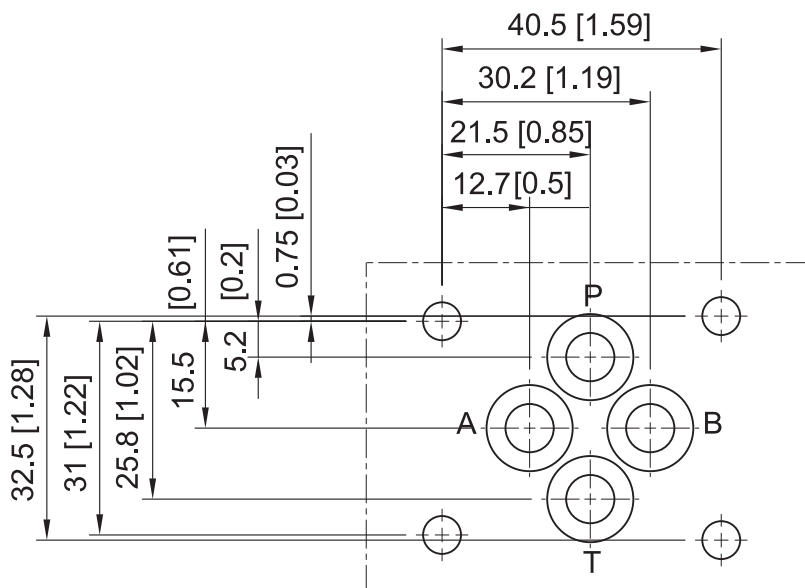

密封件 SEAL KITS

MC-02P / T

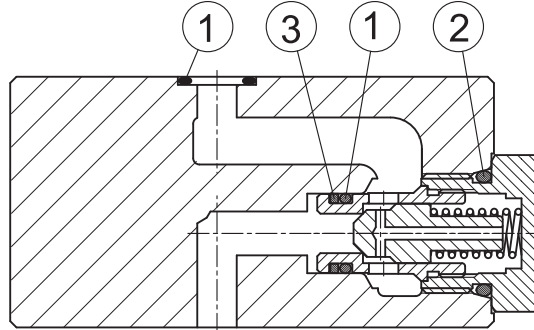

NO.	種類 Description	型號 Specification	數量 Q'ty	
			P	T
1	O 型環 O-ring	AS568-012 HS90°	5	5
2	O 型環 O-ring	P-16 HS70°	1	1
3	背托環 Back-up Ring	AS568-012 橡膠	1	1

MC-02W / A / B

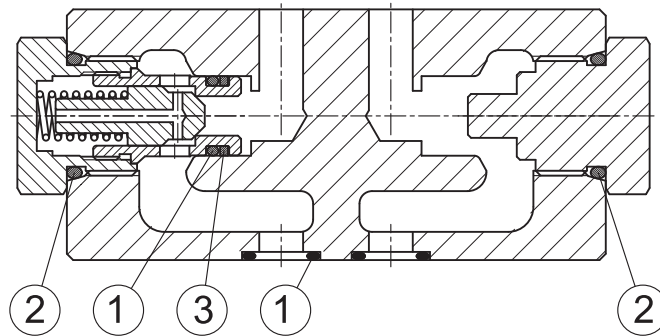

NO.	種類 Description	型號 Specification	數量 Q'ty		
			W	A	B
1	O 型環 O-ring	AS568-012 HS90°	6	5	5
2	O 型環 O-ring	P-16 HS70°	2	2	2
3	背托環 Back-up Ring	AS568-012 橡膠	2	1	1

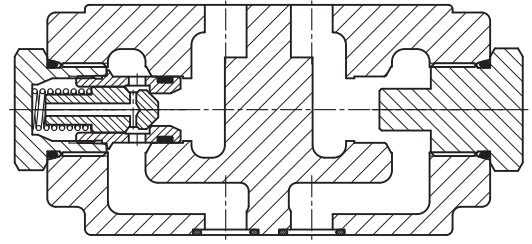

基本規格 SPECIFICATIONS

MC-03系列 SERIES		
最大工作壓力 Maximum Pressure	bar	210 bar (3000 PSI)
最大流量 Maximum Flow	LPM	70 LPM (18.5 GPM)
重量 Weight	型式 Code: P,T	2.5 Kgs (5.5 Lbs)
	型式 Code: A,B,W	2.5 Kgs (5.5 Lbs)
使用油品 Fluid Type		礦物性 耐磨性 Mineral, Anti-Wear
黏度範圍 Viscosity	cST	10-400 cST (59-1854 SSU)
使用溫度 Operating Temperature	°C	-15-70°C (-5-158°F)
清潔度 Contamination Level		NAS 12 級以內 Under NAS Class 12
表面處理 Surface Treatment		磷酸鹽皮膜處理 Zinc Phosphate Compound

型號說明 HOW TO ORDER

MC - 03 P - 05 - 40

① ② ③ ④ ⑤

① 閥系列 Valve Series
 MC = 疊加式止逆閥
 Modular Check Valve

② 通稱口徑 Subplate Mounting Size
 03 = 通稱 Nominal 3 / 8" (9mm)
 ISO CETOP5
 DIN NG10
 NFPA D05

③ 控制迴路 Control Port

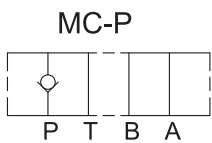

P 迴路控制
 (P Port Only)

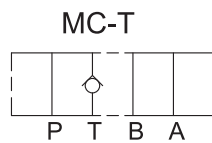

T 迴路控制
 (T Port Only)

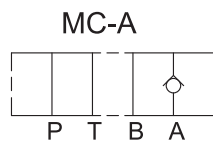

A 迴路控制
 (A Port Only)

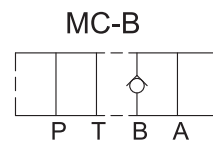

B 迴路控制
 (B Port Only)

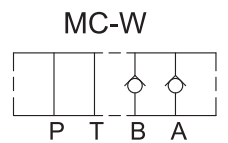

A 與 B 迴路控制
 (A & B Port)

④ 開啟壓力 Cracking Pressure
 05 = 0.35 bar (5 PSI)
 50 = 3.5 bar (50 PSI)

⑤ 設計型號 Design No.

特性曲線 PERFORMANCE

測試條件 Test Conditions

溫度 Oil Temperature: 50°C

黏度 Viscosity: 35cST(163 SSU)

壓力降特性曲線 PRESSURE DROP

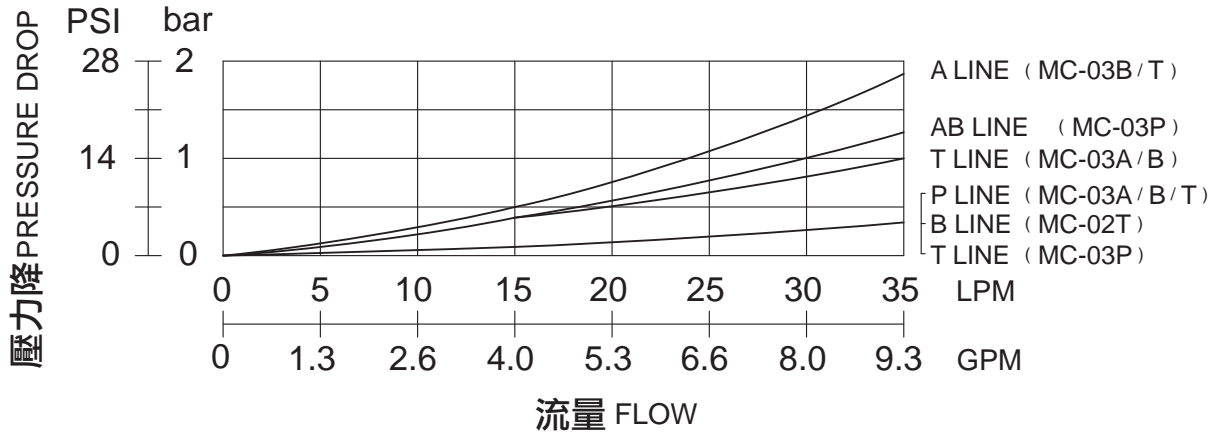

壓力降特性曲線 (自由流) PRESSURE DROP (FREE FLOW)

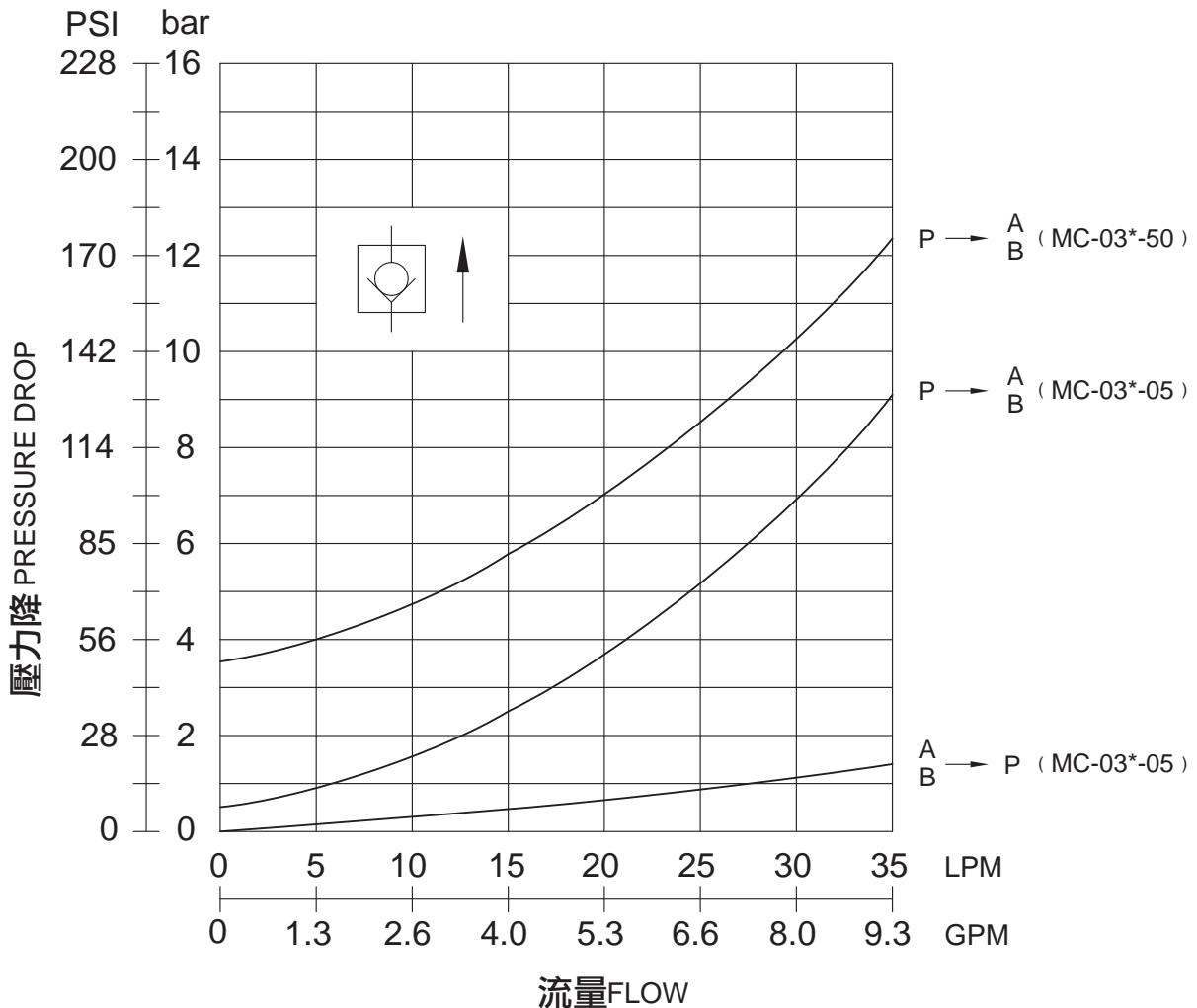

外型尺寸 DIMENSIONS

MC-03P

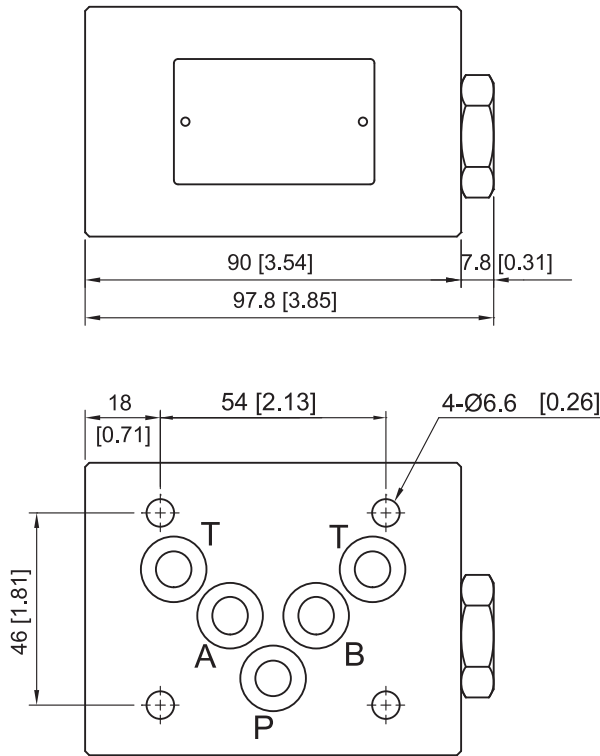

安裝面

Mounting Interface:
 ISO 4401-AC-05-4-A

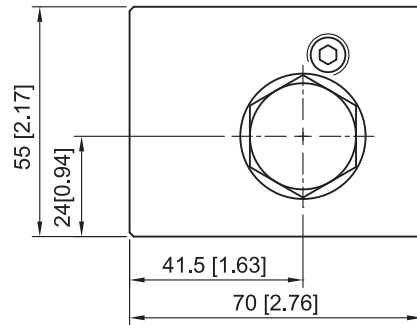

MC-03T

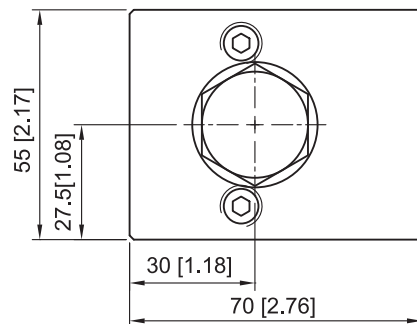
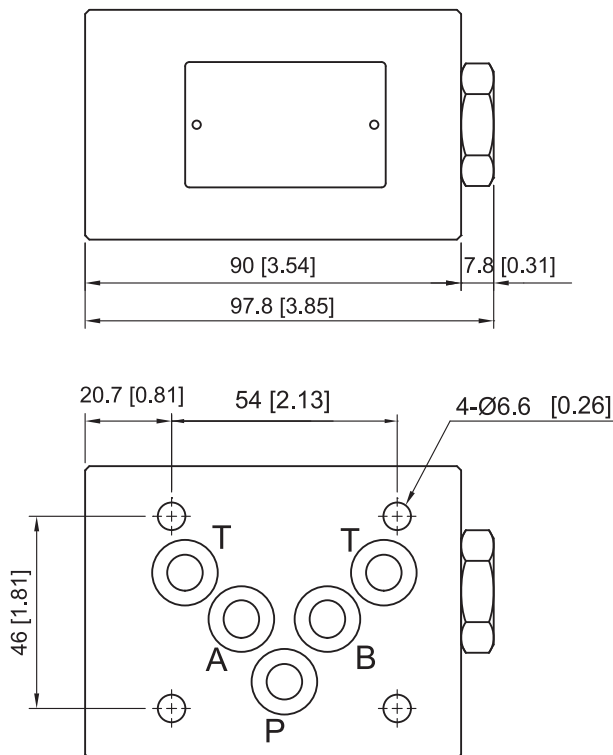

外型尺寸 DIMENSIONS

MC-03W/A/B

安裝面

Mounting Interface:
 ISO 4401-AC-05-4-A

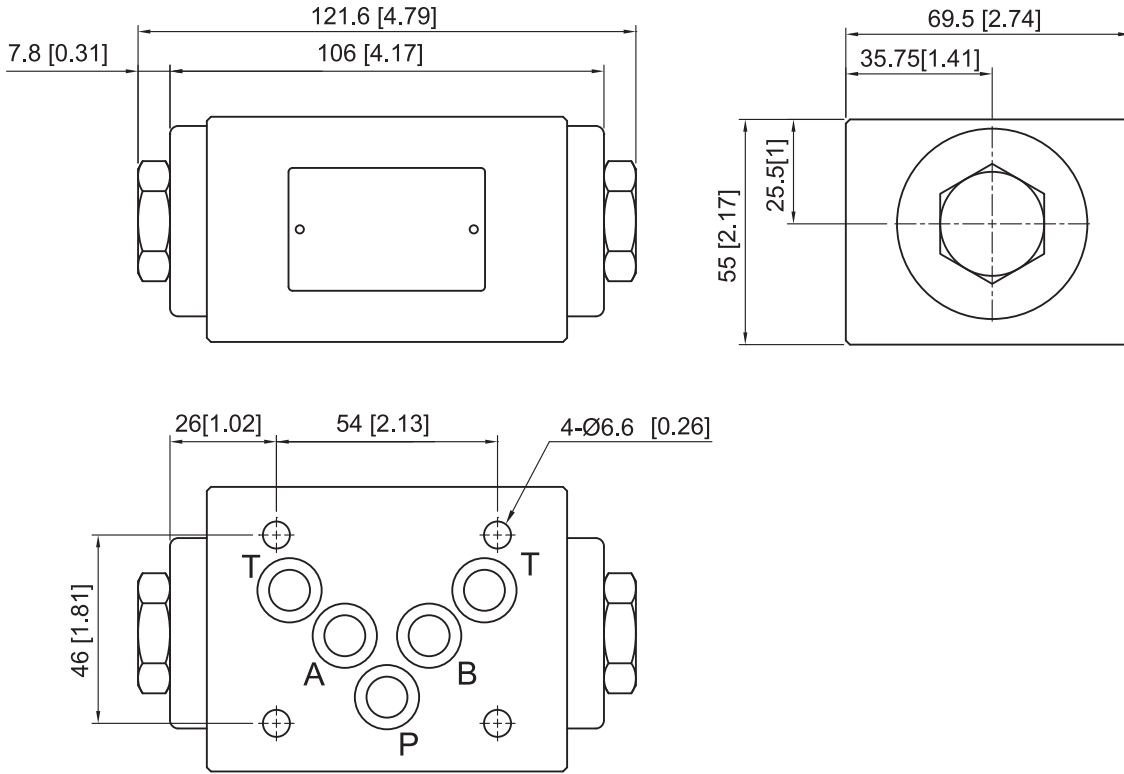

安裝面 MOUNTING INTERFACE

ISO 4401-AC-05-4-A

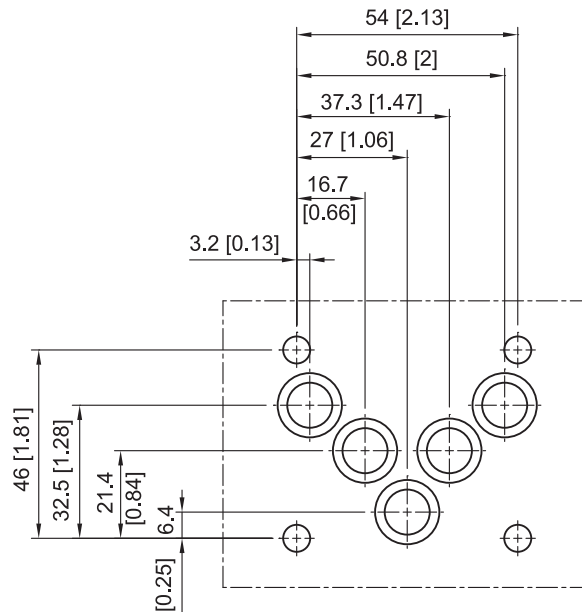

密封件 SEAL KITS

MC-03P / T

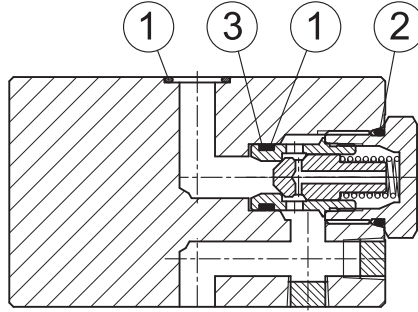

NO.	種類 Description	型號 Specification	數量 Q'ty	
			P	T
1	O 型環 O-ring	AS568-014 HS90°	6	6
2	O 型環 O-ring	P-20 HS70°	1	1
3	背托環 Back-up Ring	AS568-014 橡膠	1	1

MC-03W / A / B

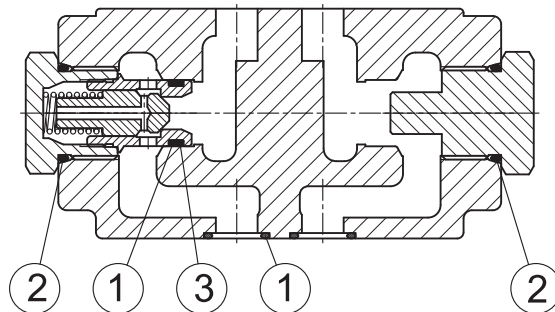

NO.	種類 Description	型號 Specification	數量 Q'ty		
			W	A	B
1	O 型環 O-ring	AS568-014 HS90°	7	6	6
2	O 型環 O-ring	P-20 HS70°	2	2	2
3	背托環 Back-up Ring	AS568-014 橡膠	2	1	1